



E Q U I P M E N T L T D

Quality Collision Repair Equipment
All Equipment delivered and installed with
competence training on site

23-24

Stanners



Contents

MIG WELDING	
Stanners 1T-S Expert	7
Stanners 3T Expert	7
Pro-Spot SP-5.3	26
Fronius TPS270i	26

SPOT WELDING	
Stanners Spot Expert	6
CTR Vision	24
Mi100 Control T With MTC6000	25

JIGS	
Quick Pull 3000 Speed	12-13
QuickJig 4000	14
Commercial 6 Metre Mobile Jig	15
QuickJig Rack 5000/5500/6000	16
QuickJig Accessories	17
UnoLiner Drive-On Benches	30-31
Wheel Stands	32

ALUMINIUM REPAIR	
Stanners Alu Stud Pull	19
Stanners Alu Arc Gas Pull	19
AluRepair Visar (VAS 852001 A)	29

MOBILE INFRA RED PAINT DRYING SYSTEMS	
EURO1000GH	22
EURO2000G	23
EURO3000G	22
Euro Range Replacement Bulbs	23

ACCESSORIES & CONSUMABLES	
Welding Spares & Accessories	44
Pulling Bridges	41-43
Alu/Steel Dent Pulling Consumables	46

DENT PULLING	
Advanced Car Body Repair System	8
Stanners Basic Car Body Repair System	9
Excalibur Tower Puller	10-11
CBR System (VAS 6321A)	28
Stanners Dent Expert ULTRA	37
Stanners Dent Expert COMBI	38
Stanners Dent Expert PRO	39
Dent Pulling Package Comparison Sheet	40
Dent Repair Tools	47

PLASTIC WELDING	
Stanners Plastic Fusion System	20

RIVETING	
Stanners TKR PNP90 Self Pierce Riveter	21
Stanners TKR XT2 Self Pierce Riveter	27
Air Rivet Guns	45
Stanners TKR XT2 accessories	48-50

ADDITIONS & EXTRAS	
Workshop Tooling	34
Painting Equipment	35
Parking Sensor Cutters	36

INDUCTION HEATING	
Stanners i3-S Heat Inductor	18
Stanners i4-S Heat Inductor	51
Stanners i13 Heat Inductor	52
Stanners i18 Heat Inductor	53

PAINTLESS DENT REPAIR	
CBR Gluing Technology	33

Miscellaneous	
About Stanners Equipment	4
Your Stanners Sales Representatives	4
Stanners Equipment Team Information	5
Training and Weld Testing	55

Sales Service Support



About Stanners Equipment

- » Stanners Equipment Ltd is a family-owned business established in 1957.
- » Over 50 years' experience supplying to UK & Ireland customers, workshop equipment and sourcing innovative technology used by vehicle body shops, car manufacturers, training centres and professional vehicle technicians.
- » Stanners have built an unrivalled reputation for supplying quality, reliable and value for money equipment. Our products are supported by a national team of sales representatives & service engineers.
- » Our products are supported by a national team of sales representatives & service engineers, we specialize in the supply of body shop equipment new and used; including inverter spot welders, MIG welders, dent pullers, heat induction, riveting tools, vehicle body repair jigs and paint curing equipment.
- » Our partner company, Stanners Specialised Services is an IMI Approved Awards Centre providing BS weld testing, ATA panel re-accreditation and bespoke aluminium training.

Stanners Equipment Team

- » **15 Inbound staff** to help with all your needs to sales, admin, logistics, service, parts and anything else we can do to assist.
- » **7 Engineers** factory trained and skilled in all bodyshop equipment repairs and servicing covering the whole of the UK.
- » **6 Sales representatives** that cover the whole of the UK, offering equipment demonstrations and providing you with efficient and effective bodyshop solutions at the best affordable prices.
- » **6 Weld Testing & Training professional's** that are IMI approved providing our customers With on site BS weld Testing, Boron Steel Awareness courses (QAA Certified and bespoke Welder Training, we can provide the whole package as a one-stop-shop.



Full UK Coverage



Stanners Spot Expert

Why the Spot Expert?

- Easy to use operator panel
- 5m Lightweight welding cable for increased reach
- Exceeds spec of BSI 0125
- Various arm sets available
- Transformer X Gun

Technical Information

- 14.000 Amp Transformer Gun
- 550 DaN tip pressure
- Water Cooled

Welding Capabilities

- Mild
- High Strength
- Ultra High Strength
- Boron
- USIBOR



MX Arms Available

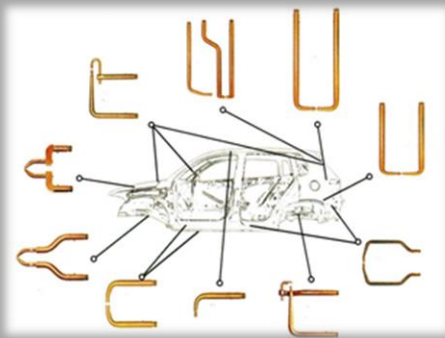

Wheel Arch
Arm Set
OPTIONAL

All the benefits of transformer gun technology without the expense of recordability. It's simple to use and will incur less servicing costs over it's lifetime.

REF:STA/SP1

Bull nose arms



550mm cranked arm



Standard short arms

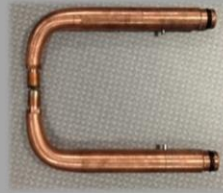

550mm straight arms



Spot expert package includes the following:

Spot Welder Spares

Flat Caps

- 12mm – REF: STA12F
- 13mm – REF: STA13F
- 16mm – REF: STA16F



Domed Caps

- 12mm – REF: STA12D
- 13mm – REF: STA13D
- 16mm – REF: STA16D





Stanners 1TI Inverter Expert

- Single or 3 Phase
- Single phase 170AMP
- 3 phase 250 AMP
- 10 Voltage Settings
- Automatic wire speed regulation to fine tune the welding process.
- The Optional Aluminium Spool Gun allows the thinnest of materials to be welded e.g. splits on wings and aluminium repairs.
- Can be set up for: Steel, Brass and Aluminium
- Has inverter technology at its core making it more energy efficient complying with new EU regulations.

Technical Information

- Current range – 20-250AMP
- Weight – 55kg
- 240v, 13AMP, Single Phase Supply

REF:AS1T-I



**Designed specifically for
the Car Bodyshop Market**

Made in Germany



Stanners 3TI Inverter Expert

Triple torch setup - no need to switch torches or liners!

- Latest 250AMP Synergic Unit
- 10 Voltage Settings. Inverter power source.
- Automatic wire speed regulation to fine tune the welding process
- Holds 2 gas bottles to the back of the unit (Pure Argon for Brass & Aluminium, and Argo shield for Steel Mig) therefore there is no requirement to swap gas bottles.
- An Aluminium Spool Gun allows the thinnest of materials to be welded e.g. Splits on wings
- Can be set up for : Steel, Brass & Aluminium
- Has inverter technology at its core making it more energy efficient complying with new EU regulations.

Technical Information

- Current range – 25-250AMP
- Weight – 70kg
- 16AMP, 3 Phase Supply

REF:AS3T-I

Advanced Car Body Repair System

Repair over replace – save money on panels and reduce key to key times.

The Advanced System is ideal for working on all vehicles, including large repairs on commercial vehicles, available with a comprehensive range of tools and a large storage trolley – complete with the new Dent Expert PRO power source.

SlideSnap 300 Puller



Rapid Tab Shooter



Slide 1000 Puller



Slide 1500 Puller

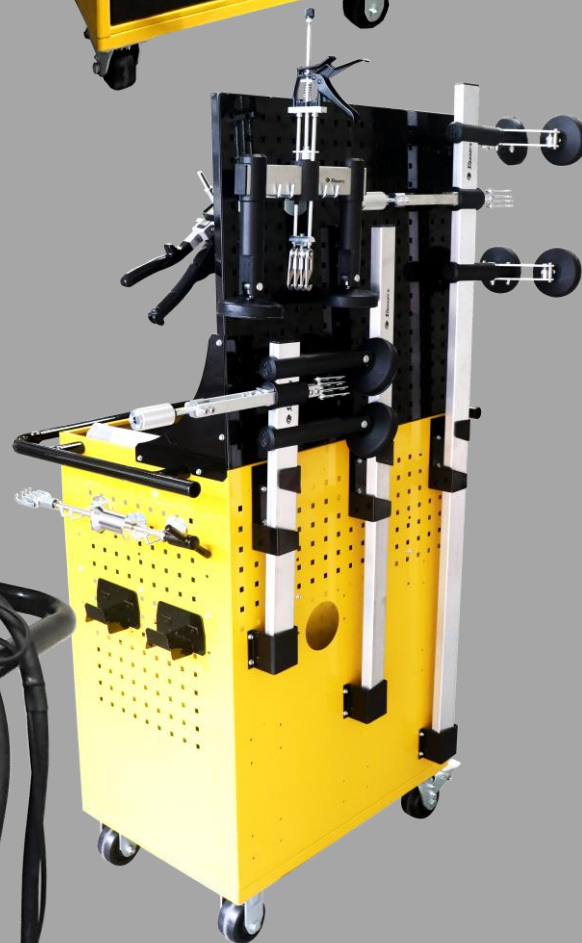

REF: STA709

Stanners Basic Car Body Repair System

The Stanners Basic Dent Pulling System contains a wide array of tools for the busy bodyshop in a compact portable package for easy movement around the workshop - supplied with the all new for 2020 - 240v Dent Expert PRO power source which offers greater consumable lifetime than traditional dent pulling units.

BS10125 Compliant

Conventional (30 Welds)



Expert PRO (200 Welds)



Slide Hammer



H Puller



Slide Hammer + Claw

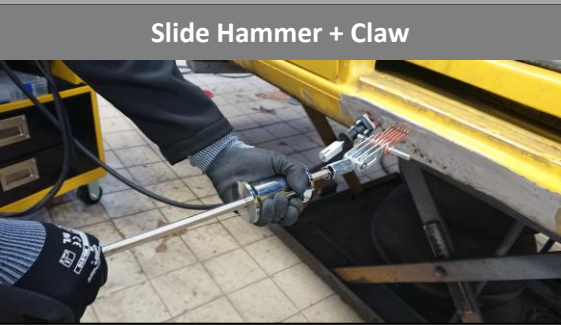

Quick Puller (4 Pad Options)



Lever Puller



Slide 600 Puller



REF: STA707

Excalibur Tower Puller

Excalibur is a smart pulling system for straightening external metal panels on damaged cars. It's Quick and easy to use, using compressed air to develop a vacuum effect that ensures perfect adhesion to the floor without needing additional support or fixing points.

The system has a manual hoist that develops a traction force of 250 kg, and it's the ideal aid for straightening thin sheets through slotted washers or glue systems.

Easy to install and manoeuvre, it represents an indispensable tool for reducing working times in the body.



Pull ratchet with easy adjustable height

**AVAILABLE IN TWO
SIZES 1.34M & XL
1.7M**

Technical Specifications (Standard)

- Vacuum ejector at 4 bar. Air Pressure Requirements: 2.83CFM
- Made with high quality aluminium. Weight: 15.5kg.
- Maximum working height 1300mm
- 250kg pull force with ratchet
- Rubber outlet to seal the base.
- Equipped with a wheel system to give it full mobility.

REF: STA580I FOR XL & STA580 FOR STANDARD

Some Examples Of Types Of Repairs Excalibur Can Make

BS10125 Compliant

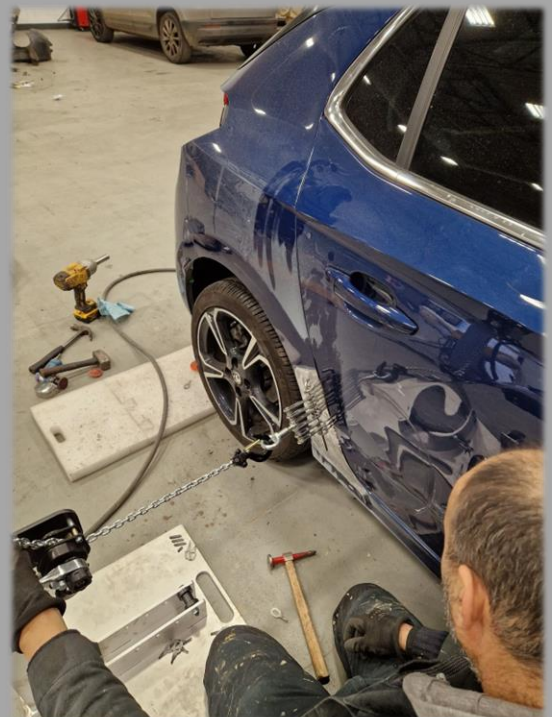

Quick Pull 3000 Speed

The Quick Pull 3000 **Speed** is used in fast repair work for light body collision repair/maintenance/diagnosis for vehicles with high working efficiency.

The four adjustable lifting arms move in 180°, allowing the bench to be used as a scissor lift, making it easy to use on nearly all vehicles. The swivel dozer has multiple pulling angles and heights including downward pull and can be moved 360° around the bench, always achieving maximum pulling force, no matter what height.

Includes full chain and pulling clamp kit. For cars without sills e.g. BMW, Mercedes-Benz and Renault, sill adaptors are available to hire.

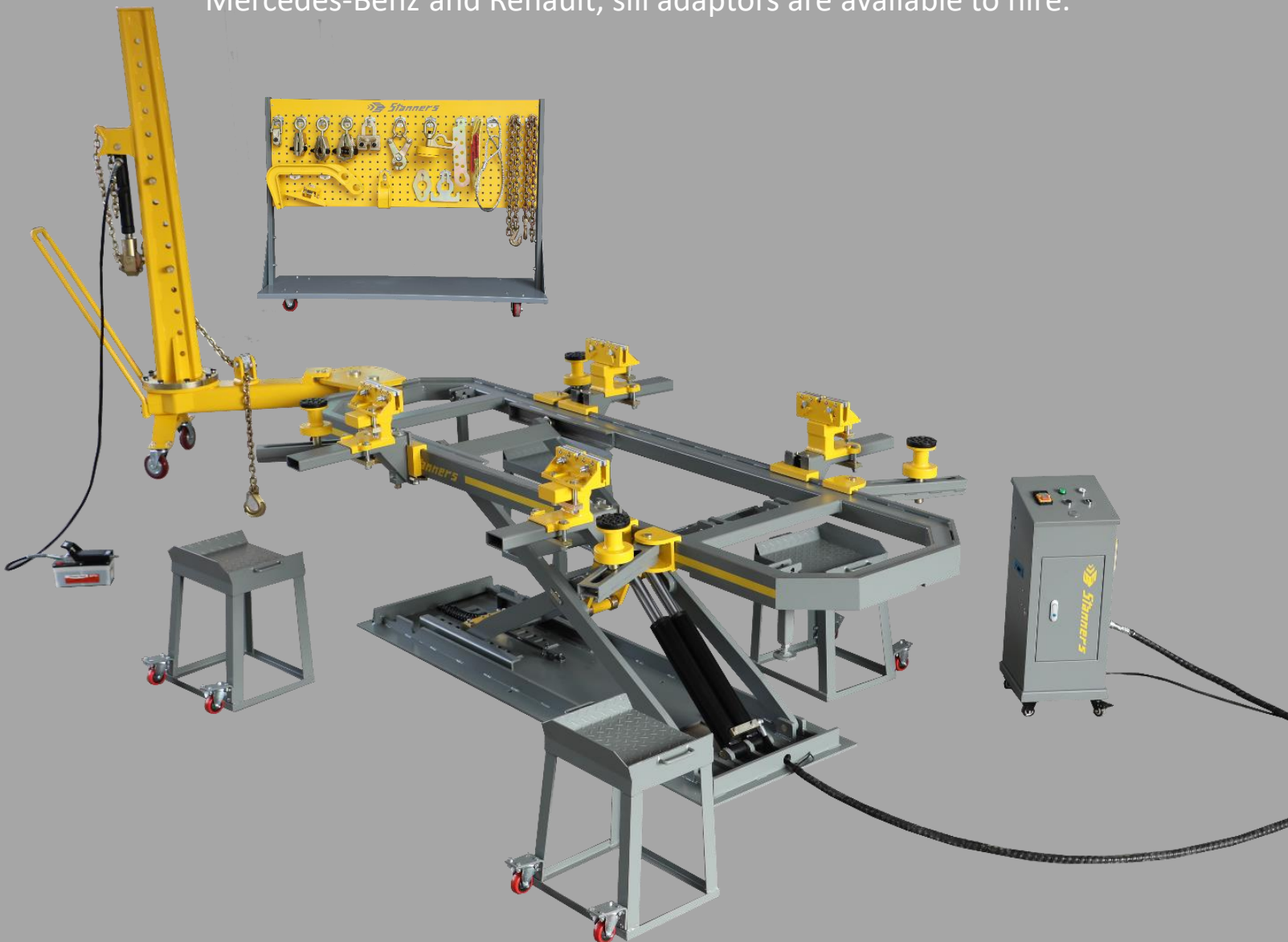

REF:STA510

Technical Specification

Voltage	400v 3-Phase
Frequency	50Hz
Frame/Lift Height	110mm / 1400mm
Max Pulling Force	6 Tonne
Max Lift Capacity	3 Tonne



Watch this product in action!

https://youtu.be/dhDC7H_piBg

BS10125 Compliant

Wheel Buckets REF:STA520

Set of 4x Heavy Duty Wheel Buckets for supporting a vehicle.



Sill clamp arms feature vertical adjustment

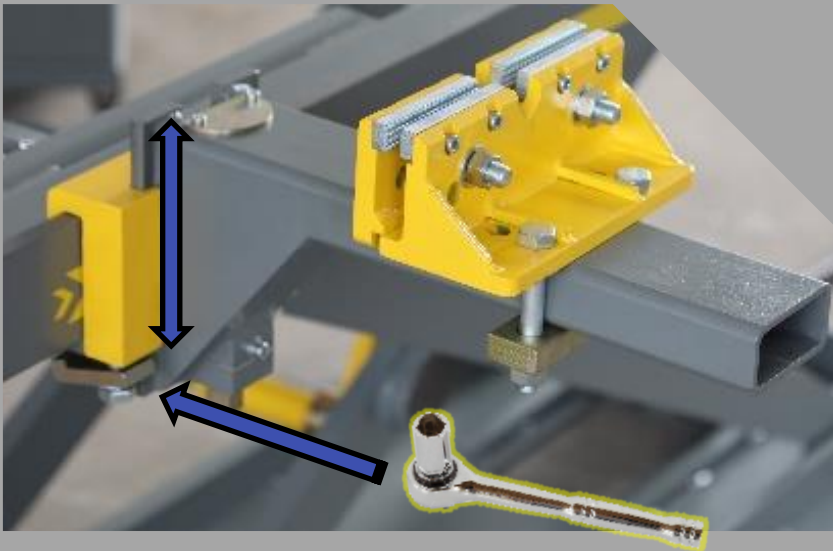

Raised sill clamp arms allow measurement to take place



Multiple pulling angles and heights, including downwards pull

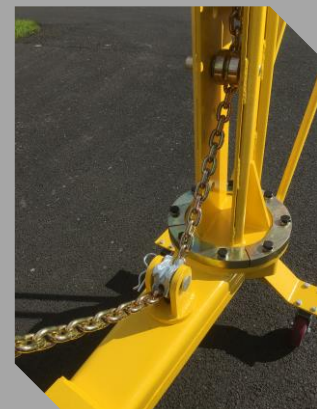

QuickJig 4000

With the option of 2x 360 degree pulling towers offering 10 ton pulling force anywhere around the jig, this versatile jig can also be used as a scissor lift, lifting from 260-1600mm.

Supplied with various pulling clamps, hooks and tools, and with an electronic hydraulic pump, the QuickJig 4000 can be operated quickly. The multifunction folding ramps allow the vehicle to be supported whilst the vehicle is clamped up for repair.

Technical Specification:

Frame Length:	4160mm
Frame Width:	950mm
Frame: Height:	260-1600mm
Max Pulling Power:	10 Ton
Rated Voltage:	220v-380v
Working range of Tower:	360°
Max Load:	4000kg



Drive-On Wheel Ramps REF:STA519

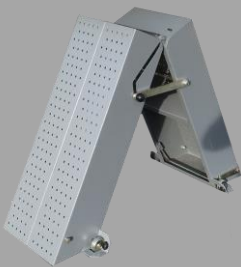

Set of 4x Heavy Duty A-Frame Drive-On Wheel Ramps which can be folded to support vehicle.

<https://youtu.be/j43TECuUzyY>



Watch this product in action!

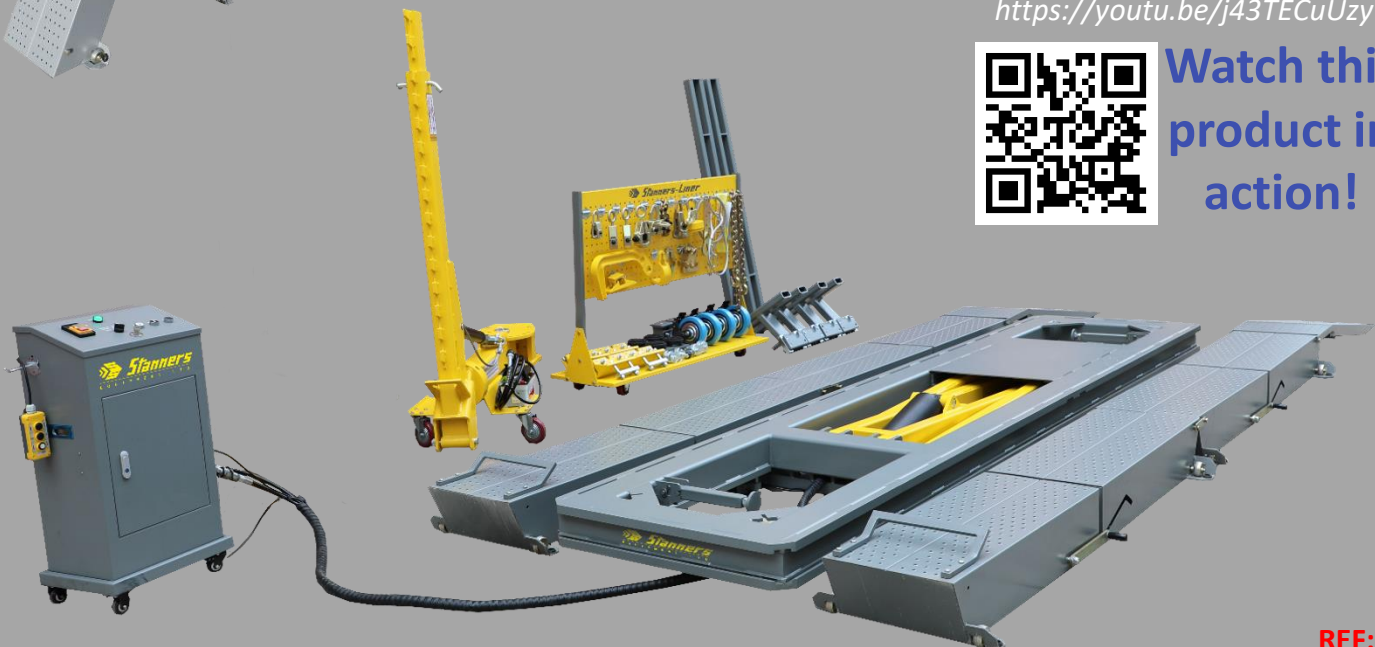

REF: STA514

Commercial 6 Metre Mobile Jig

BS10125 Compliant

Stanners Mobile jig is the space saving wheel-mounted jig system that also allows disabled vehicles to be moved into different locations. These may include into a clean room, or into a less congested area of the bodyshop.



QuickJig Rack 5000/5500/6000

This system is available in 3 different lengths with option of a bench up to 6 metres in length.

With a single 360 degree pulling tower (option of a second tower) offering 10 ton pulling force anywhere around the jig, this versatile jig can also be used as a scissor lift, lifting from ground up to 1190mm.

Supplied with various pulling clamps, hooks and tools with an electro hydraulic pump, the Quick JigRack can be operated quickly.

The tilting function and drive on boards allow the vehicle to be supported whilst the vehicle is clamped up for repair.

Choice of 3 Frame Lengths!
Up to 6 metres!

Technical Specification:

Choice of Frame Length:	5000/5500/6000mm
Frame Width:	1170mm
Frame Height:	Up to 1190mm
Max Pulling Power:	10 Ton
Rated Voltage:	415v
Working Range of Tower:	360 Degrees
Max Load:	4000KG

QuickJig Rack 5000 5.00Mtr – **REF: STA525**

QuickJig Rack 5500 5.50Mtr – **REF: STA526**

QuickJig Rack 6000 6.00Mtr – **REF: STA518**

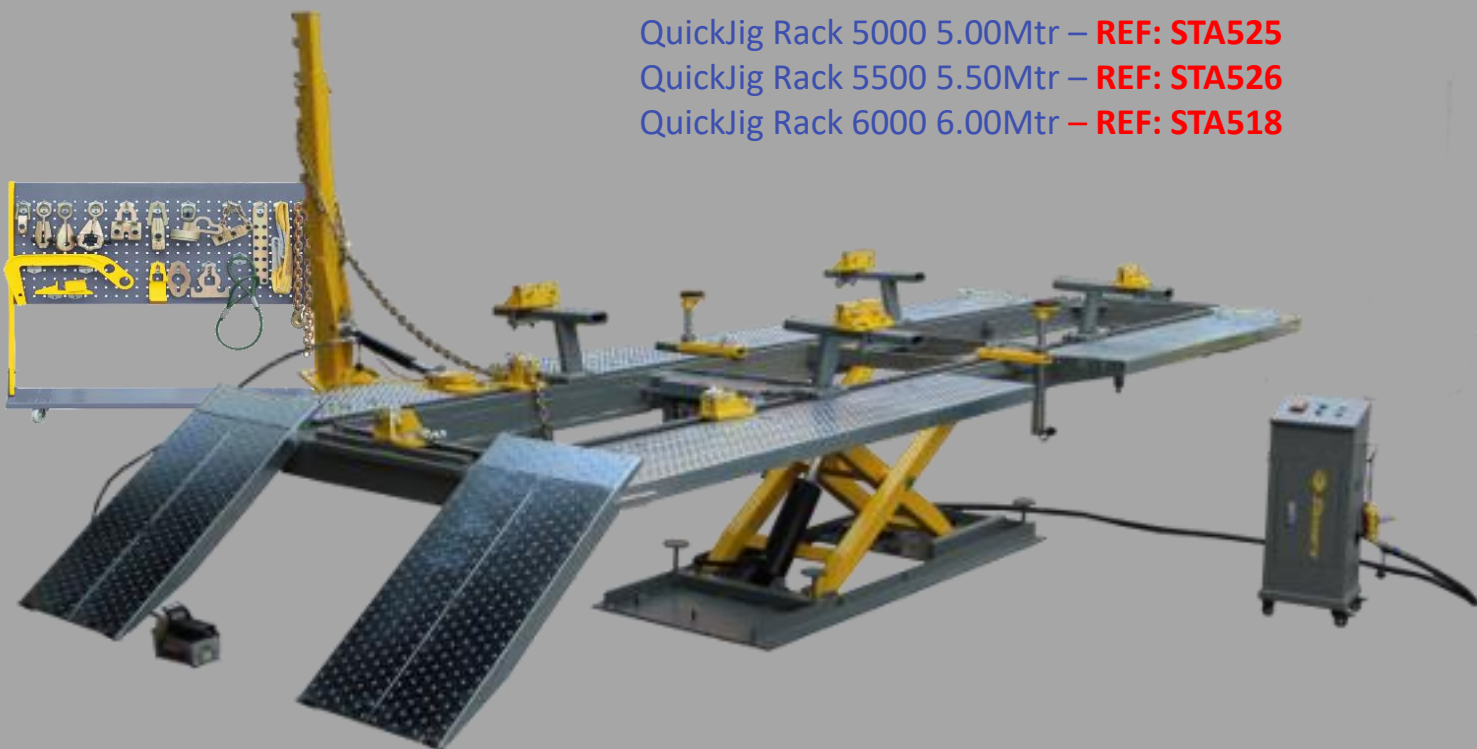

Using the JigRack in tilted form, the vehicle can be easily driven on.

The tilting end can then be levelled out to a horizontal position.

At this stage, the vehicle can be raised.

The vehicle can be fixed in place by using the main sill clamps.

Collision repair can be performed after pulling tower installation.

QuickJig Accessories

BS10125 Compliant

Quick Jig Trolley

REF:STA522

1. Mini Clamp
2. Small Clamp
3. C Clamp
4. Wide Clamp
5. Right Angle Clamp
6. Heavy Duty Clamp
7. Chain Pull Clamp
8. Strut Puller Kit
9. Double Connector
10. Multi Hole Pull Plate
11. Cable Sling
12. x2 Chain Hook 1.2M
13. Pull Hook Set
14. Deep Hook
15. C Claw

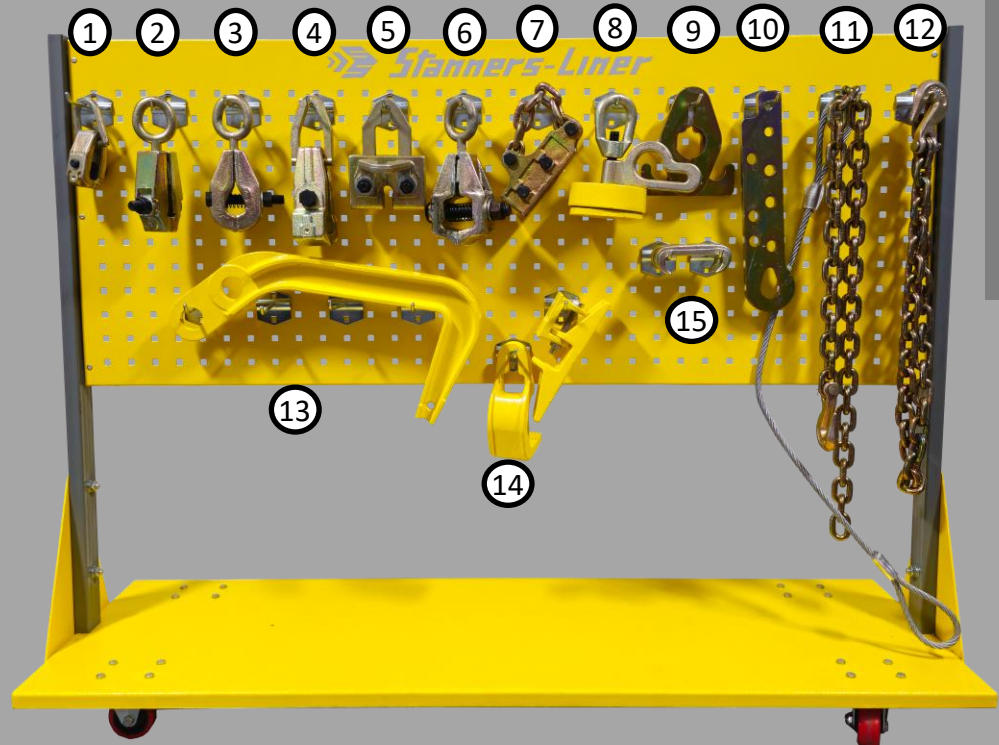

Merc/BMW Clamps REF:STA513



Set of Mercedes and BMW Support Clamps.

Support Beam REF:STA521

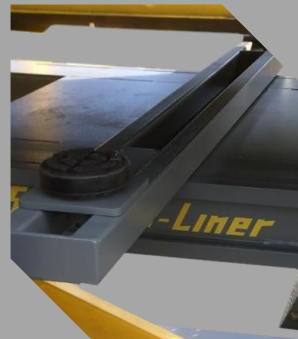

Set of 2x Heavy-Duty Universal Support Beams for cross-bench lifting of vehicles, complete with 4x Supporting Pads.

Merc/BMW Clamps REF:STA5001

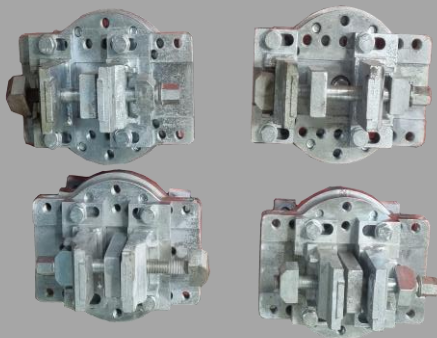

Set of Holding Supports

4x4 Holding Kit REF:STA512



Set of 4x4 Holding Supports.

Stanners i3S- Heat Inductor

The i3s is a fully portable, 230v 16A induction heater with 5 power settings specially designed for use the bodyshop is very lightweight meaning it can be carried from one job to the next. The simple controls of the i3s make it easy to use, and allow for fast and efficient results. The i3s is water cooled , giving it an excellent duty cycle.



UNIQUE BENEFITS

- 7x4 cm character digital LCD control display
- Dial selector control knob used to adjust the power intensity
- Power board unit
- Foot pedal accessory with cable
- Heating glove accessory with cable
- Water Cooling

APPLICATIONS

The I3S heat inductors are ideal for a wide range of applications such as:

- Heated rear windows
- Side windows
- Mouldings
- Adhesives and stickers without residues paint
- Sealants and/or sound insulation materials
- Tar liner
- Structural glue

Technical Features

Certifications: CE, UKCA
 Frequency: 50/60Hz, 19KHz
 Supply voltage: 230 V
 Fuse: 16 A
 Output: 3000W
 Protection category: IP 21
 Length x width x height: 340x190x210 mm
 Net weight: 5 kg



Optional
Heating Glove



Optional
Glass Remover

REF: STA/i3s

Stanners Alu Stud Pull

The Stanners Alu Stud Pull unit offers the following features:

- Traditional capacitor discharge aluminium stud puller – welds small aluminium studs onto the damaged panel, allowing keys to be fitted and pulled using the bridge puller
- The pulling stud welds to the surface of panel, there is no burn through to rear side of panel.
- No need to remove trims or re-paint rear side of panel.
- Stud is removed from panel by twist action using a pair of side cutters.



REF: STA705

BS10125 Compliant



360 Pull Ring Kit
(10xM4 + 10xM6)
REF:STA736



M4x15mm Alu Studs
Pk.25 Al-Mg - REF:STA744
Pk.50 Al-Si - REF:STA743



M6x15mm Alu Studs
Pk.25 Al-Mg - REF:STA746
Pk.50 Al-Si - REF:STA745

Stanners Alu Arc Gas Pull



Stanners offers the latest aluminium dent puller in our range.

New fusion welding technology – the advantage of our new Alu Arc Gas Pull system over more traditional units is that it welds an aluminium key to the panel like a steel dent puller for much stronger dent pulling over larger areas.

The unit also uses pure argon gas to shield the welding process and create a cleaner weld to the surface of the aluminium panel.

The result is a quicker process and much stronger weld giving the ability to do larger repairs (within reason) to aluminium panels over traditional older aluminium dent systems.



Alu Straight Keys
Pk.50 Al-Mg - REF:STA758
Pk.50 Al-Si - REF:STA757



Alu Twisted Keys
Pk.25 Al-Mg - REF:STA762
Pk.25 Al-Si - REF:STA761

REF:STA700

Stanners Plastic Fusion System

Repair damaged bumpers + more!

The Plastic Fusion System comes complete with 2 torches.

One for inserting hot staples for rebuilding and reinforcing broken plastic as well as a hot iron for melting larger cracks - the other torch for melting filler plastic to the cracked workpiece.



Option to use Gas/No Gas

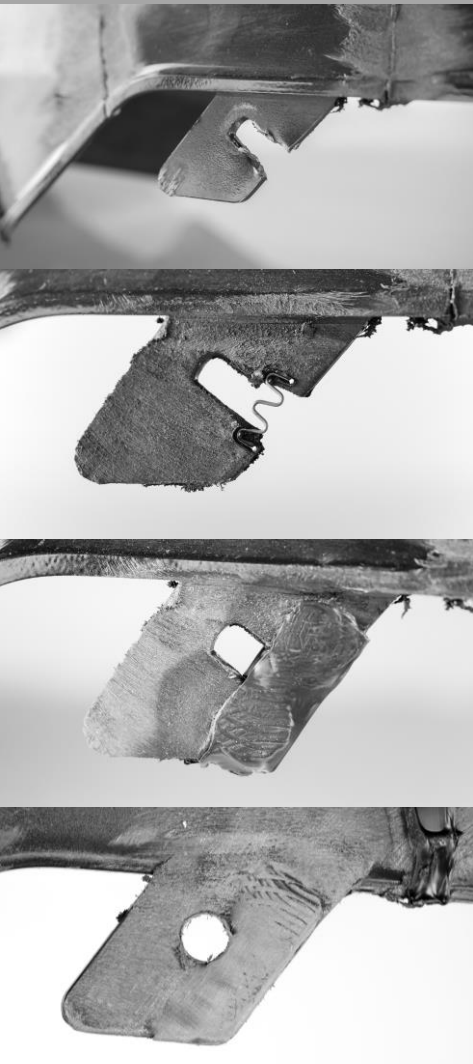

The Stanners Plastic Fusion System provides a fast, cost effective repair option for plastics. It has been designed for high quality, strong and fast repairs in the automotive sector. With the optional user-controlled supply of nitrogen gas to eliminate oxidation/fumes during the weld process, this creates a strong, high quality repair.

Using weld strips and steel reinforcing clips, it is possible to repair snapped tabs, cracks and splits, saving the cost of new bodywork and reducing workshop expenditure.

With this system, you can repair cracks, reinforce with hot staples then reach a set temperature with a small volume of air or nitrogen, fill the damaged part quickly and efficiently creating a strong, permanent and high quality repair using the provided melt strips.

Able to use Nitrogen for the strongest possible weld!

REF: STA771

Stanners TKR PNP90 Self Pierce Riveter

BS10125 Compliant



Why use the PNP90?

- There is less surface preparation as transport primer, sealer or stone chips (on sills) do not have to be removed and no weld thru primer applied unlike spot welding.
(Repair times are being reduced for the cold repair process)
- Better for corrosion warranty as e-coatings are not removed or burned away
- As there is no heat generated with rivets they can join UHSS/BORON steels without weakening the steel
- Unlike spot welding, riveting does not cause sparks avoiding damage to interiors and glass
- Holds structural adhesive in place as it cures
- Easy removal of Rivet Clamp by releasing locking pins
- Blind Rivet Attachment now available!
- Flow Form Rivets
- 6 Ton Compression Force

BMW Approved

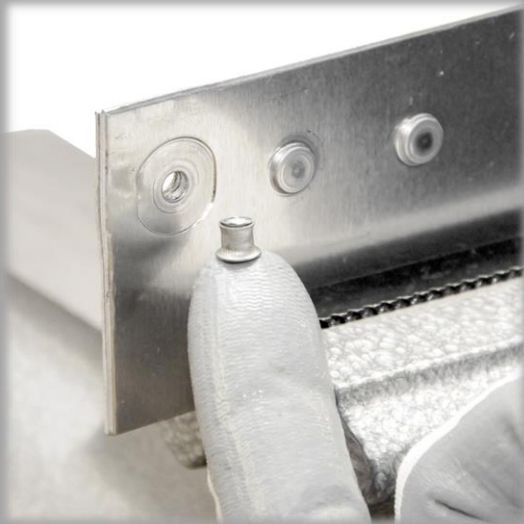

Pressing Out Rivets

Old or defective rivets must be removed from the sheet metal when repairing panels. Using the extraction die and mandrel, these can be pressed out, minimising damage and avoiding drilling of the rivet.



Flow Form Rivets

Using the punch and die, you can set flow form rivets without even drilling the panel, both piercing the panel and closing the rivet in one seamless operation.

REF: TKR-STA-URK-V2

Mobile Infra Red Paint Drying Systems



*Digital
Readout and
Controls*



EURO1000G

- Strong, Lightweight stand with 4 swivel castor wheels, making it easy to manoeuvre round the workshop
- Adjustable height on trigger latch of 1.75m
- Single cassette, 1kw Power output.
- Easily adjusted into a variety of positions to achieve optimal surface area temperature

Input Power: 240V, 1 Phase

Power: 1000W

Time Setting: 0 - 60 min

Temperature: 30 - 100°

Curing Area: 800 x 450 mm

REF: EURO1000G

EURO3000G

- Strong, Heavy Duty stand with 4 swivel castor wheels, making it easy to manoeuvre round the workshop.
- Adjustable height on trigger latch of 1.75m
- Triple cassette, 3kw Power output.
- Easy to use controls with a digital readout.
- Easily adjusted into a variety of positions to achieve optimal surface area temperature.

Input Power: 240V, 1 Phase

Power: 3x 1000W

Time Setting: 0 - 60 min

Temperature: 40 - 100°

Curing Area: 1200 x 1000 mm

REF: EURO3000G

Mobile Infra Red Paint Drying Systems

BS10125 Compliant

EURO2000G Configurations



Digital Readout and Controls



Large Panel

Sill Section



Corner

EURO2000G

- Strong, Lightweight stand with 4 swivel castor wheels, making it easy to manoeuvre round the workshop.
- Adjustable height on trigger latch of 1.75m
- Double cassette, 2 Kw Power output.
- Easily adjusted into a variety of positions to achieve optimal surface area temperature.

Input Power: 240V, 1 Phase

Power: 2x 1000W

Time Setting: 0 - 60 min

Temperature: 30 - 100°

Curing Area: 800 x 800 mm

REF: EURO2000G

New Euro1000GH/2000G Bulb

REF:EURO1001G



New Euro3000G Bulb

REF:EURO3001G



Older Euro1000/2000 Bulb (Red Bulb Jacket)

REF:EURO1001



Older Euro3000 Bulb (Red Bulb Jacket)

REF:EURO3001



CTR Vision

Fully Automatic Multifunction Spot Welding Machine

Latest Generation



The Multifunction spot welding machine in the premium class with complete software package for worry free automotive repair! Fully automatic welding particularly of components made of high maximum strength and also coated and laminated steel panels.

Aluminium welding for thin aluminium sheets up to 3 mm.

Manufacturer approval
Tesla

- >Voltage: 3 x 400 V / 50 Hz
- >Max. power: 130 kVA
- >Welding process-control software Virtual Machine (VM)
- >Easy and quick exchanging of C- and X-gun
- >Cooling power: 1000 W
- >Reproducible welding quality
- >Dimensions: 1220 x 680 x 800 mm
- >Weight approx.: 95 kg

All required welding tasks performed by a single device:

- Spot welding in automatic mode without prior adjustments
- Conventional spot welding in standard mode with setting of current and time
- Spot welding with quality assurance and energy control:

Welding programs for coated panels and panels still containing traces of paint or adhesive residues, including independent parallel resistance detection system and stabilizing control as well as vehicle

specific programs with approved parameters of vehicle manufacturers

- Spotting, dent repair, pulling of steel plates, welding on of pins And T-pins (with optional spotter)



REF: STA10006 X-GUN
ADAPTER
c/w ANGULAR ARM'S

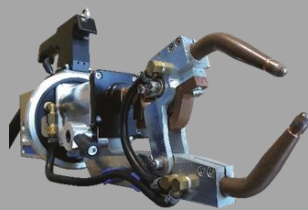

REF: STA10005 X-GUN
ADAPTER c/w

Spot Welder Spares



REF: ELM9013454
Electrode Cap For Spotter



REF: ELM9013304
13mm Electrode Cap -
Standard

REF: STA10000

Mi100 Control T With MTC6000 Gun With True Auto Mode VAS 821 201

The Spot Welder that covers every UK Approval and Specification



Stanners takes the worry out of welding with TrueAutoMode: Industry's First Fully Automatic Spot Welding System

Stanners introduces worry-free welding with the collision repair industry's first fully automatic spot welding system: TrueAutoMode. TrueAutoMode automates the welding process to provide perfect, OEM-approved spot welds every time.

TrueAutoMode measures weld resistance approximately 1,000 times per second and automatically adjusts current level, weld time and clamp pressure as needed. It provides instant feedback to the technician if there's a bad weld and can log every weld. At the end of a job, a TrueAutoMode Mi100 Control T welder can print out a report that includes information on the settings, messages and actual weld parameters of every weld, enabling a shop to easily document that its welds were made correctly.



OEM Approved Equipment

Manufacturer approvals inc.

Ford, Honda, JLR, Opel, Mercedes Benz, and VW Group

Use: Spot welding of structural body damage. Specially designed for high-strength steels such as Boron, TWIP, USIBOR, TRIP, XIP.

Process Reliability: Intelligent control technology allows a spot weld quality that is comparable to the quality achieved during the production process of new vehicles.

Protection of the Investment: The modular nature of the system means the system can be easily upgraded for future requirements. Quick and easy tool change; new OEM welding programs can be added through software updates via compact flash card.

Efficient Spot Welding: The simple "MULTISPOT" operating concept requires only brief instructions and allows efficient operation of the equipment. The optional PC-software provides analytical capabilities i.e. to check the efficiency of the welding process.

Full Traceability: The spot welder logs every weld with full information of the parameters and actual weld characteristics for full traceability.

Lightweight Transformer C Gun
5m Cable
14,000 Amps
Water Cooled Unit
600 DaN Tip Pressure
Lower Power Consumption
Fully Automatic Weld Control
Optional Wifi download with barcode scanner for Job Sheets

160 C arm



90 C arm



C arm electrodes



330 C arm



550 C arm



Arms and accessories available such as:

REF: ELE520508

Pro-Spot SP-5.3

The NEW Pro Spot SP-5.3 Double Pulse MIG Welder was designed with microprocessor controls and weld programs specifically geared for the collision repair industry. Applications include Aluminium MIG, MIG Brazing, Steel MIG/MAG, Root Welding, TIG, MMA/Stick Welding, etc.

- Multi-Torch System -3 dedicated MIG torches and spools that make switching materials as easy as grabbing a torch!
- Double Pulse Technology -Allows for precise heat control and weld aesthetics. Great for vertical welding!
- 3 Phase Power -Maintain arc stability on the thickest to the thinnest materials.
- SMART Software -Welding is as easy as grabbing the torch and clicking the trigger, the software changes to the correct weld settings and gas automatically.
- Updates & Upgrades -Keep your welder updated via USB port.
- User Defined Memories -Save and recall more than 200 working points and store them in a customized job list.

Technical Information

- 3ph/400v supply
- MMA 5A-270A
- TIG 5A-350A
- MIG 20-350A
- IP23S Rated
- Fan Cooled
- **Tesla Approval**



REF: STA406

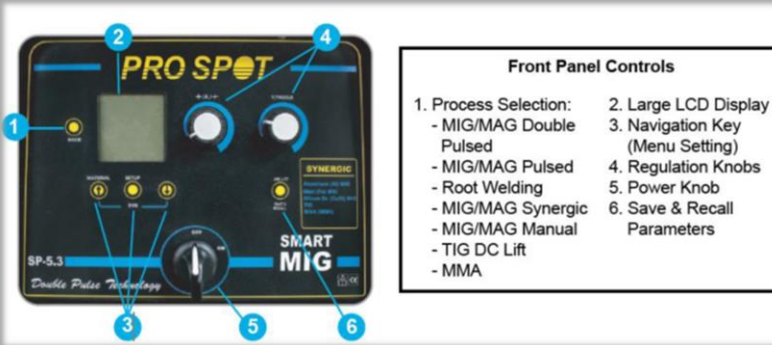

Fronius TPS270i MIG Welder

What are the Manufacturer Approvals and Specifications for this?

This machine reaches BS10125 Specification and has manufacturer approval from Mercedes Benz, VW, Audi (for Aluminium Welding), Seat, Skoda, Kia, Peugeot, Renault, Citroen, Toyota, Hyundai, Honda, Fiat, Alfa Romeo, Suzuki, Mazda, JLR.

Technical Information

- 3 Phase supply
- 3-270AMP
- Mercedes Benz Approval



REF: FR4.075.170.830

Stanners TKR XT2 Self Pierce Riveter

OEM Approved Equipment

Stanners introduce future-proof TKR XT2 riveter

With the increasing need for bonding and riveting operations in body repair to join aluminium and a mix of materials, it is essential to have the correct tooling capable of performing a wide range of riveting styles at the right pressure.

The TKR XT2 is the strongest mobile hydraulic tool for bodywork repair. All extensions are based on the existing PNP90 UN2.0, compatibility with existing riveting tools is possible.

With infinite adjustment of the working pressure and up to 10t of compression force and 8T of tension force, the TKR XT2 is a versatile and lightweight necessity for any workshop.

Heads are available for JLR, Audi, BMW, and Mercedes Benz.

Upgrade your existing PNP90 to the new TKR XT2!
Part Ref: **TKR-STA-227**

Length	330mm
Width	260mm
Height (incl. Handle)	213mm
Weight	10.6kg
Max Input Pressure	6 bar/ 87psi
Max. Operating Pressure	600 bar
Operating Force	10 Ton Compression/ 8 Ton Tension

**TKR XT2 Riveter
Mercedes Benz + JLR
Manufacturer
Approved**

Training Available

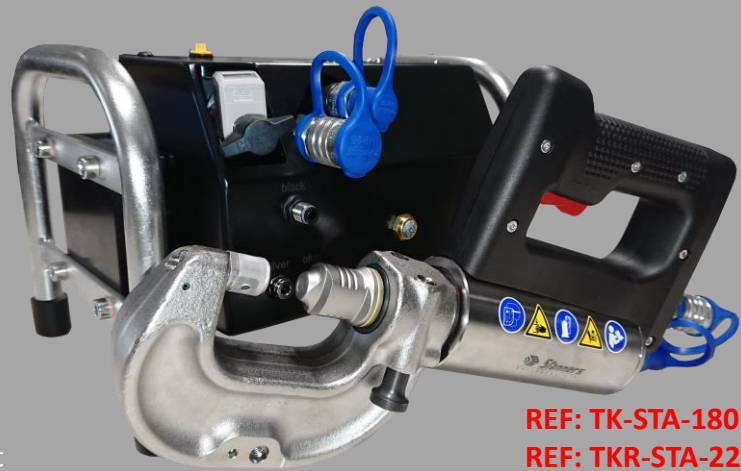

REF: **TK-STA-180 : Basic Kit**
REF: **TKR-STA-226 : JLR Kit**

TKR XT2 Standard Kit

The TKR XT2 standard kit comes in heavy duty carry cases and is composed of the following:

- Punch Rivet Kit – Mercedes
Part No: **TKR-STA-167**
- Flow Form Rivet Kit – Mercedes
Part No: **TKR-STA-168**
- 3.5mm + 5.00mm Rivet Kit – BMW
Part No: **3.5mm – TKRBGR-24**
Part No: **5.0mm - TKRBGR-23**
- Trolley (if required)
Part No: **STA169**
- PNP90 SNW XT2 Pump
Part No: **TKR-STA-38**
- Gun and small 45mm C Arm
Part No: **Gun – TKR-STA-41**
Part No: **45mm C-Arm – TKR-STA-1085**
- Duo Hose Package (XT2)
Part No: **TKRBGR-1128**
- M8 to M6 adaptor (for 10T/6T head interchange)
Part No: **TKR25-73 Adaptor**
Part No: **TKR25-74 Distance Bolt**
- Short adaptor for accessibility
Part No: **TKR25-107**



CBR System (VAS6321A)

The brand new CBR consists of pure carbon and carbon fibre reinforced plastic components with an innovative honeycomb structure. Thanks to the unrivalled ergonomics of the incredibly light and yet extremely resilient pulling tools, repairers can straighten better and faster in the shortest possible time.

REPAIR INSTEAD OF RENEWAL COMPLETELY REDEFINED

It has never been easier to achieve perfect repair results and more added value than with this high-quality complete workstation for modern bodywork repairs. With 12 pulling tools and more than 500 accessories, the CBR System offers the most flexible and complete car body repair workplace on the market. It is the main base for all repairs on steel and aluminium panels.

THE COMPLETE WORKSTATION FOR STEEL AND ALUMINUM

The extremely low weight of the CBR pulling components considerably reduces the effort required for everyday straightening work. A panel beater can easily work alone with the Strong- or Line-Tool. Compared to other systems, the application of the pulling tools – especially when working overhead – is radically easier and absolutely fatigue-free. The newly developed pulling components and extensive accessories give the repairer considerably more flexibility in the repair process, whether on passenger cars, SUVs or commercial vehicles.

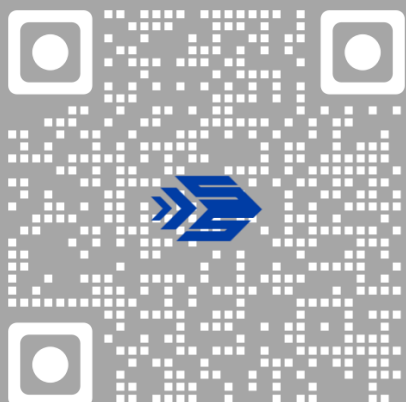

Scan The Code To Watch The Amazing CBR System In Action Repairing A Aston Martin GT4.

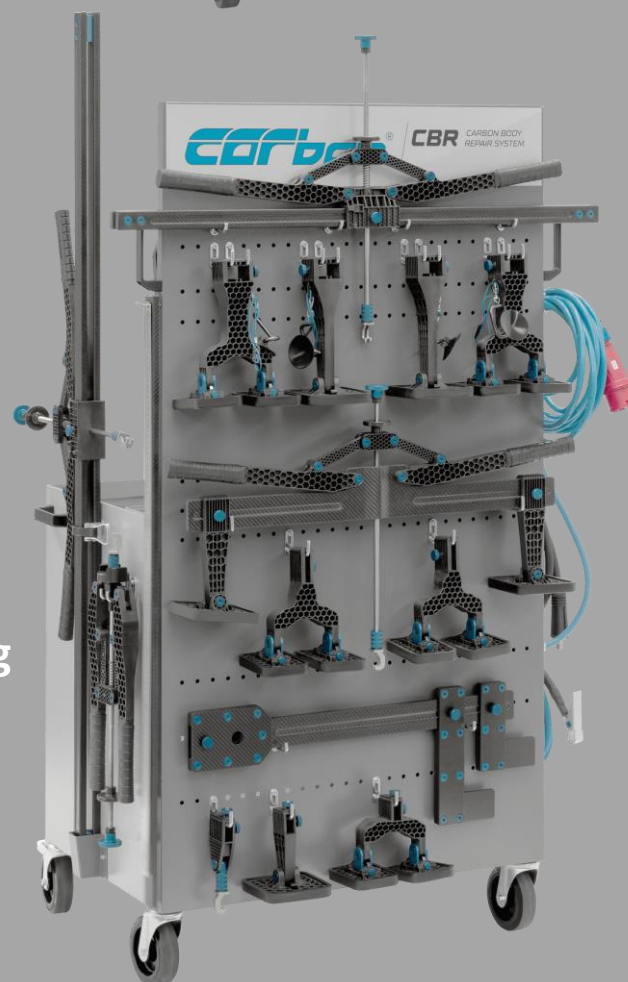

REF: VAS6321A

AluRepair Visar (VAS 852001A)



With the proven, absolutely process-safe drawn arc method with up to 1,200 A welding current and the patented welding gun, various types of studs can be welded on a wide range of steel and aluminium alloys.

- Higher output: 1,200 A
- Thread, ground, and tool support bolts up to \varnothing 12 mm
- Remove body punch rivets efficiently and cleanly
- With parameter library
- Industry 4.0 capable

Technical Data

Welding area	\varnothing 2 – 12 mm, M3 – M12
Welding material	Steel (unalloyed and alloyed), aluminium
Welding current	1.200 A (max)
Current setting range	25 – 1.200 A
Welding time	5 - 1.500 ms (infinitely variable)
Connection	200 to 600 V, 3 phases, 50/60 Hz
Type of cooling	F (thermally controlled ventilator)
Protection type	IIP 23 (use in the open air also permitted)
Ambient air temperature range	0 °C to 40 °C
Dimensions	430 x 288 x 246 mm (without cable)
Weight	18,5 kg

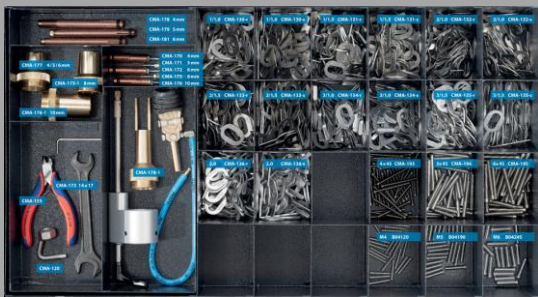

REF: VAS852001A

STUD WELDING

In addition to welding the Miracle aluminium bits, the AluRepair plus system is ideally suited for welding mass, threaded, standing and tool support bolts made of steel, stainless steel or aluminium. Due to the high device power of 1,000 A, bolts up to \varnothing 10 mm can be set safely.



PUNCH RIVETS PULLING

Body parts are often joined by punch rivets at the factory. The attachment of stainless steel bolts with the AluRepair plus system for a clean pulling of the rivets is faster, cleaner and easier than the complex drilling of the connection points.



UnoLiner Drive-On Benches



The UnoLiner Drive-On Benches combine Drive-On Ramps with a vehicle lift and chassis straightening bench for quick and easy collision damage repair. The car or truck can stay on its wheels while it is lifted to working height. Our Wheel Stands & Quick Lock Chassis Clamps ensure the car or truck is accessibly placed and anchored to the frame machine bench system and ready for body and chassis straightening within 10 minutes. Since the first UnoLiner chassis straightening bench's construction, we have further developed and perfected our collision repair workshop equipment. We offer body shop and panel beater professionals the repair equipment they need. UnoLiner produces conveniently low Drive-On benches that can be placed flat on the workshop floor. No bench angling swing systems or winches are needed to roll cars onto a UnoLiner bench. All of this results in a multifunctional solution for every workshop.

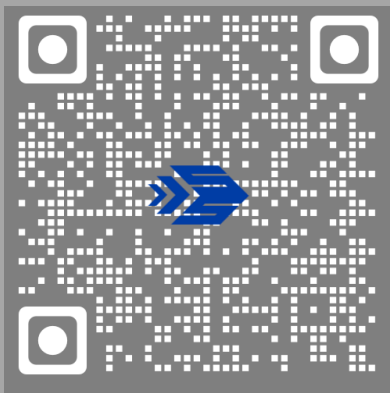

Scan The Code To Watch The UnoLiner Jig Videos From The YouTube Channel



Features

- >Low bench height
- >Mechanical and hydraulic safety systems
- >60 or 100 cm drive-on ramps
- >3, 4.6, 5, or 6 ton lifting capacity
- >Bench frame lengths of 4, 4.6, 5.5, or 6 meters
- >Multiple-angle 10-ton pulling ability
- >Interchangeable UnoLiner accessories

Technical data

- >Total length : 3795-7140mm
- >Standard width per lane : 450mm
- >Weight per section: 12-16 kg
- >Angled drive section: 600 or 1000 mm
- >Max load per ramp section: 1000-1500 kg

Wheel Stands

The STA547 Standard Wheel Stand is notable for its sturdy and practical design, a full set supporting vehicles from compacts to pickup trucks. Casters add mobility to the stands, allowing easy placement.



Technical Data

Height : 830 mm
 Width : 535 (635) mm
 Length : 605 mm
 Weight : 25 kg
 Max. load weight : 850 kg



REF: STA547

The STA518 Wheel Stand is the heavy-duty version of the STA547 Wheel Stand. Thanks to its reinforced design, its maximum capacity has increased to 1400 kg per stand. This renders the STA518 the perfect wheel stand for the bigger bench systems. Casters add mobility to the stands, allowing easy placement.



Technical Data

Height : 830 mm
 Width : 635 mm
 Length : 605 mm
 Weight : 32 kg
 Max. load weight : 1400 kg



REF: STA518

Scan The Code To See How The Wheel Stands Work With A Jig

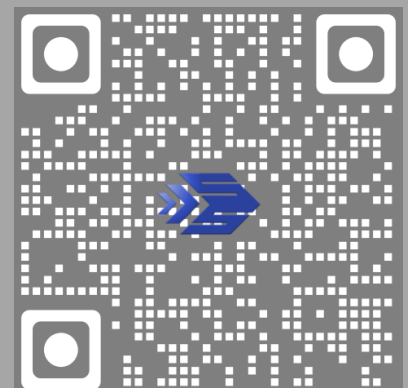

CBR Gluing Technology

Additions & Extras

INCREDIBLE FAST PREPARING

More than half of motor vehicles registered in UK have dents and dents that you can remove easily and profitably with the paintwork damage-free dent removal technique. With dent removal as an additional service, you increase customer loyalty and attract new customers to your business.

The gluing technique is ideal for damage to sills, side panels, hoods or the rear part. Up to 80% of the deformation can thus be formed back in an extremely short time.

SENSATIONAL RESULTS AFTER ONLY 10 MINUTES!

Round deformations without body edges are pulled flat by the large-area connection of the gluing pads with the panel metal. Thus this you can pull out the material softer and gentler.

The gluing technique is ideal for damage to sills, side panels, hoods or the rear part. Up to 80% of the deformation can thus be formed back in an extremely short time.

The gluing technology perfectly complements the already existing tensile components and the Airpower pneumatic press. The glue set is usually amortized as a result of the high time savings in the repair of the first damage.



REF: VAS6321/1

Gluetech Kit



Gluetech+ Kit

REF: CARMGT-400



Workshop Tooling

Spot Weld Removal Drill (Order ref: DF5120)

This drill has a patented pneumatic spindle drive for constant drill pressure. It drills out the entire spot weld. It has a detachable hook and an adjustable depth stop. Due to the automatic drill-pressure the application becomes more ergonomical and efficient while the life-time of the drills increases. This piece adheres to continuous drill-depth regulation. **Standard and Boron Steel Spec. Available**



Softgrip Low Vibration Airsaw (Order ref: STA600)

This very light Air Body Saw weighing in at around 0.6 kg is perfect for the regular user looking for a professional body saw. This Air Body Saw features include; low vibration, high cutting capacity and adjustable rear exhaust for precision cutting under maximum control.



Air Belt Sander (Order ref: C3610)

10mm x 330mm Air Belt Sander – comes with 2 spare belts.



3/8 Air Drill with Auto Chuck (Order ref: D6011)

3/8 Air Drill with Auto Chuck, simple operation with forward or reverse option for drilling.



1/4 Inch Air Die Grinder (Order ref: I6650)

1/4 Inch Air Die grinder with collet backing pad fastener, suitable for a wide range of heads.



Burraway One-Pass Deburring Tool (6.5mm Order ref: STA14)

(4.5mm Order ref: STA15)

For Blind Rivets

The Burraway is supplied fitted with a double acting blade to deburr both sides of a drilled hole. This can be done using portable power tools with no special operator skills required.

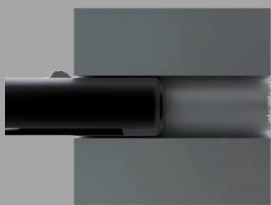

Upon entry, spring tension holds the cutting blade in the extended position as it removes the burr on the front of the hole.



As the feed load increases, the pre-set spring tension is exceeded and the blade retracts automatically as the tool passes through the workpiece.



Spring tension again causes the blade to extend as it emerges from the ID of the part; the burr is removed on the back side of the hole on the return stroke.



In one single pass, both sides of the workpiece have been easily deburred. The crowned and polished top surface of the blade will not mar the inside surface of the hole.

Painting Equipment



Universal Panel Stand

- Strong heavy duty Universal panel stand with 4 swivel castor wheels, making it easy to manoeuvre round the workshop.
- Rubber panel rests for protection of parts from marking.
- One piece moulded locks, height adjustable
- Width is fully adjustable for all bumper/door/panel sizes.
- When not in use, stand can be folded flat for easy storage.

REF: STA203

Bumper Stand

- Strong heavy duty stand with 4 swivel castor wheels, making it easy to manoeuvre round the workshop
- One piece moulded locks for support rods, height adjustable
- Width is fully adjustable for all bumper/door/panel sizes.
- When not in use, stand can be folded flat for easy storage.

REF: STA204



Specialist Tooling



Stanners is able to provide you with comprehensive tool kits to meet manufacturer's requirements (and colour coded if necessary for audit tool cross-contamination requirements)

Stanners can take the hassle out of individual tool purchases and provide you with everything you need.

Enquire with our office for more information.



Parking Sensor Cutters

PRESS-IT 2.0 Punch perfect holes into bumpers - without effort.

The Press-it parking sensor cutting kit is designed for punching holes into bumpers to mount parking sensors. Previously, holes were generally drilled by stepped drill bits. The problem is, that the bumper is unusable if the hole is cut too large.

The advantage of the Press-it System is that pressing in the holes takes place after the painting. The lacquer is moved in at the edges and as a result, there are no sharp edges. Because the sensitivity of the sensors, they have to be fixed in millimetre precision to guarantee a proper function. By using the mandrels, which are also included in the Press-It kit, the sensors are assembled in a very precise way to manufacturers requirements for a professional, repeatable quality, time after time.



Press-It 2.0 Basic Kit

Order Ref: STA181

Comprising of the following:

- Handle with ball bearing
- 18.2mm Punch and Mandrel
- 24.0mm Punch and Mandrel
- 26.0mm Punch and Mandrel
- 32.0mm Punch and Mandrel
- 10.0mm Drill
- Case with inlay

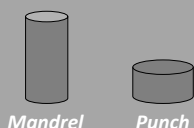

		BMW	VOLKSWAGEN	SKODA	OPEL/VAUX
	18.0mm – STA182			✓	
	18.2mm – STA198	✓	✓		
	18.4mm – STA201		✓		
	24.0mm – STA202				✓
	26.0mm – STA199		✓		
	26.5mm – STA205		✓		
	26.7mm – STA183		✓	✓	
	27.4mm – STA183-T2			✓	
	28.1mm – STA183-T3		✓	✓	
	29.3mm – STA206		✓		
	32.0mm – STA207	✓			
	32.5mm – STA208	✓			
	38.9mm – STA183-T4		✓		



Press-It 2.0 Full Kit

Order Ref: STA175

Comprising of the following:

- Handle with ball bearing
- 18.0mm Punch and Mandrel
- 18.2mm Punch and Mandrel
- 18.4mm Punch and Mandrel
- 24.0mm Punch and Mandrel
- 26.0mm Punch and Mandrel
- 26.5mm Punch
- 26.7mm Punch and Mandrel
- 27.4mm Punch and Mandrel
- 28.1mm Punch and Mandrel
- 29.3mm Punch
- 32.0mm Punch and Mandrel
- 32.5mm Punch
- 38.9mm Punch
- Manual
- 10.0mm Drill
- Case with inlay

Optional Extra: Press-It 2.0 Ford Edition set!

Stanners introduces the new Ford specific mandrel set in addition to the Press-It bumper cutting kit!

The kit contains a range of 10 sizes of high quality mandrels specific to the Ford Marque.

Press-It 2.0 Ford Edition

Order Ref: STA240



Stanners Dent Expert ULTRA

With its tiny dimensions and powerful transformer, the Dent Expert Ultra is ideal for quick use around a busy workshop, small enough for a space limited workshop or light enough for the mobile technician on the road.

The ultra is a very lightweight steel dent pulling unit with **extra long lightweight cables** that uses high power and very short weld time. The result is **no burn through** on the inside panel which is better for corrosion prevention in the future.

The unit has the option of its own bespoke trolley.

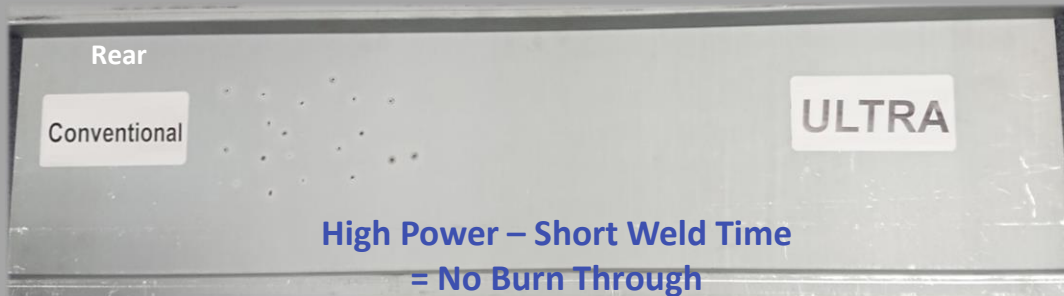
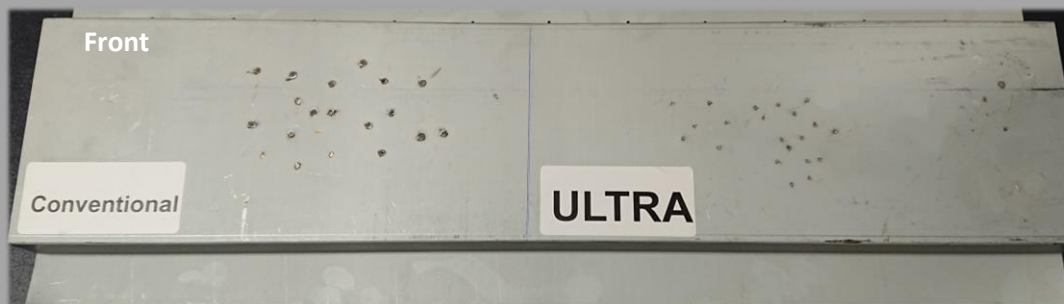

Short Weld Time – Better Corrosion Protection



New high-durability contact tip offers far greater life than normal pulling electrodes. After 200 welds, the tip is only starting to show light wear and is still working well!

Consumables last up to 5 times longer than traditional machines

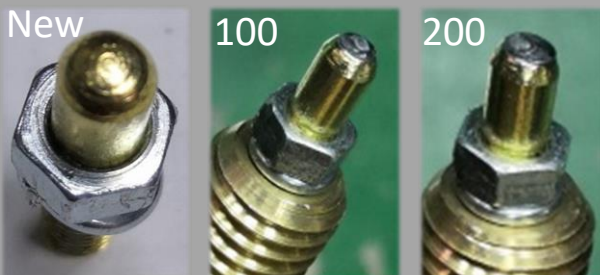

Technical Specification:

Power Input:	1PH 240V 3A
Maximum Output:	5000A
Weight:	7.2KG (9.16KG with Gun+Earth)
Torch Length:	3 MTR
Earth Length:	2.5MTR

REF: STA703

Stanners Dent Expert COMBI

Steel and Aluminium in one unit.

The Stanners Dent Expert COMBI is a versatile twin gun power unit for removing dents on both steel and aluminium.

Complete with a range of tooling for both materials including a rapid pulling bridge, H puller for on-gun instant dent pulling, rapid tab shooter for fast key fixing to the panel and more.

Your Kit Contains:

- Power Unit
- Weld-On Slide Hammer
- H Puller
- SlideSnap 300 Rapid Puller
- Quick release Push-On Earth
- Rapid Tab Shooter
- Steel/Alu Consumables Box including carbon rods, keys and studs etc.
- Steel Weld Gun
- Aluminium Stud Gun

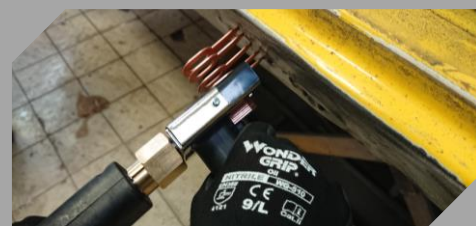

REF: STA712

Stanners Dent Expert PRO

Additions & Extras

– Ideal for small smart repairs

The Stanners Dent Expert PRO, further improving on one of our most popular units, the Stanners Dent Expert.

Perfect for repairing dents in steel, this kit comes with a range of accessories.

Kit Contains:

Power unit

Weld-on Slide Hammer

Quick Release Push-On Earth

Carbon Tempering Rods

Wavy wire+Tool

Straight+Twisted Keys+Tool

Washers+Triangles+Tool



Quick twist-release Earth has stronger contact than traditional single point earth electrodes!



REF: STA706

Dent Pulling Package Comparison Sheet

	Alu Stud Pull	Alu Gas Arc Pull	Dent Expert Combi	Dent Expert Ultra	Dent Expert Pro	Basic Car Body Repair System	Advanced Car Body Repair System
Aluminium Hammer Set		✓					
Aluminium Studs	✓	✓	✓				
360 Pull Ring Kit	✓	Optional	Optional	Optional	Optional	Optional	Optional
Aluminium Keys		✓					
Small Accessory Box	✓	N/A	✓	✓	N/A	N/A	N/A
Small Trolley	✓	✓	✓	Optional	Optional	✓	N/A
Large Accessory Box	N/A	✓	N/A	N/A	✓	✓	✓
Large Trolley	N/A	N/A	N/A	N/A	N/A	N/A	✓
Quick Puller + 4 Pads	Optional	Optional	Optional	Optional	Optional	✓	✓
Pulling Rods	✓	✓	Optional	Optional	Optional	✓	✓
Slide Hammer			✓	Optional	✓	✓	✓
H Puller			✓	✓	Optional	✓	✓
Rapid Tab Shooter			✓	Optional	Optional	Optional	✓
Slide Hammer + Claw			Optional	Optional	Optional	✓	✓
Lever Puller			Optional	Optional	Optional	✓	✓
SlideSnap 300	✓	✓	✓	Optional	Optional	Optional	✓
Slide 600						✓	✓
Slide 1000							✓
Slide 1500	Optional	Optional	Optional	Optional	Optional	Optional	✓

Refurbished Units

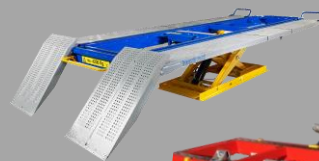

Stanners offer a wide range of second hand, refurbished welders and Jig beds and other equipment for sale. As our stock changes regularly, give us a call or take a look on our eBay page for details on our current stock. Just scan the QR Code



Pulling Bridges

Stanners offers a modular range of pulling bridges with our new Dent Pulling range.

Slide 600 Puller REF:STA773



Bearing mechanism offers fine control of dent pulling.

600mm Length adjustable pulling bridge with 4 hook claw.

2.9KG

SlideSnap 300 Puller REF:STA763



300mm Length adjustable Rapid squeeze puller with 4 hook claw.

Adding more pullers to the Slide series bridges offers more distributed pulling strength than traditional single pulling bridges

2.3KG

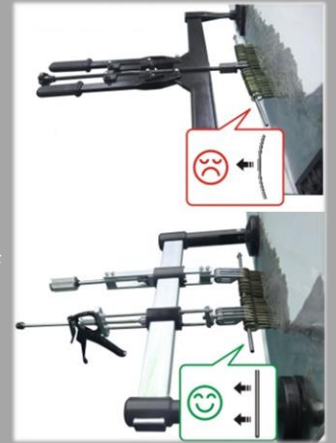

Slide 1000 Puller REF:STA774

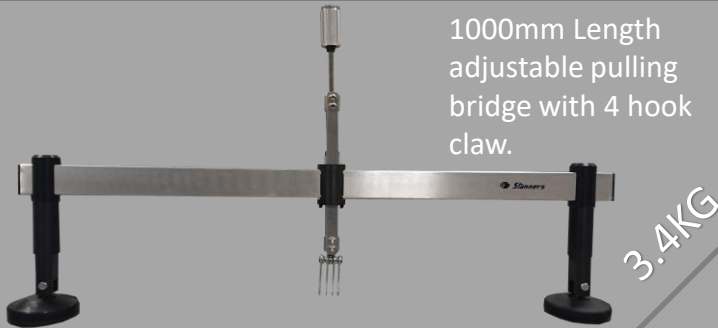

1000mm Length adjustable pulling bridge with 4 hook claw.

3.4KG

Slide 1500 Puller REF:STA710



Knurled handle gives a comfortable grip and option of using a Hex Key/Power Tool for added control and speed.

1500mm adjustable twin-foot heavy duty pulling bridge with 4 hook claw.

4.9KG

Side Winder System

- Controlled pulling force applied by turning screw handles at each end of the pulling beam.
- Magnetic and suction feet allow the tool to be used on vertical or horizontal panels.
- Swivel feet allows positioning on corners or curved panels for exact positioning.
- Extendable pulling beam from 150mm to 1600mm allows work on small or large panels
- Special mounting brackets enable mounting of puller to pull rocker/sill panels, corner edges etc.

Optional Extras

This kit has an extensive range of accessories pulling attachments!
Please ask for more info!



Bridge fitted with additional Double Swivel Feet and rapid puller



Slide 600 Puller REF:STA773

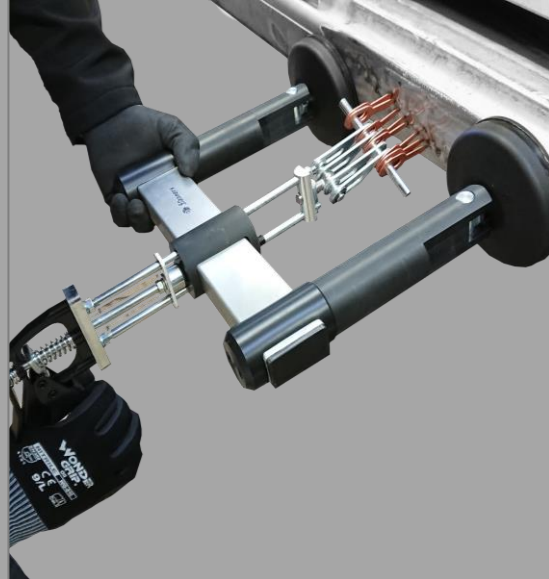

SlideSnap 300 Puller REF:STA763

Bridge fitted with additional Double Swivel Feet



Slide 600 Puller REF:STA773

Each Slide Puller bridge attachment has smooth Ball-Bearing action for ease of use.



Bridge fitted with additional pulling claw for larger repairs



Slide 1500 Puller REF:STA710

MODULAR DESIGN
Each puller can be customized to your needs

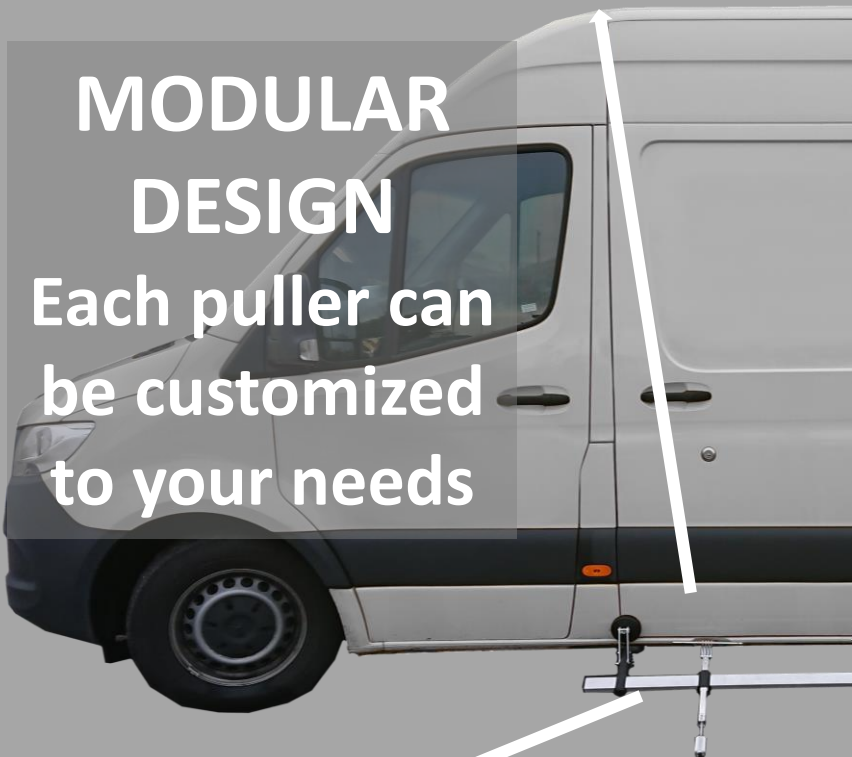



Slide 1500 Puller **REF:STA710**



Slide 600 Puller **REF:STA773**

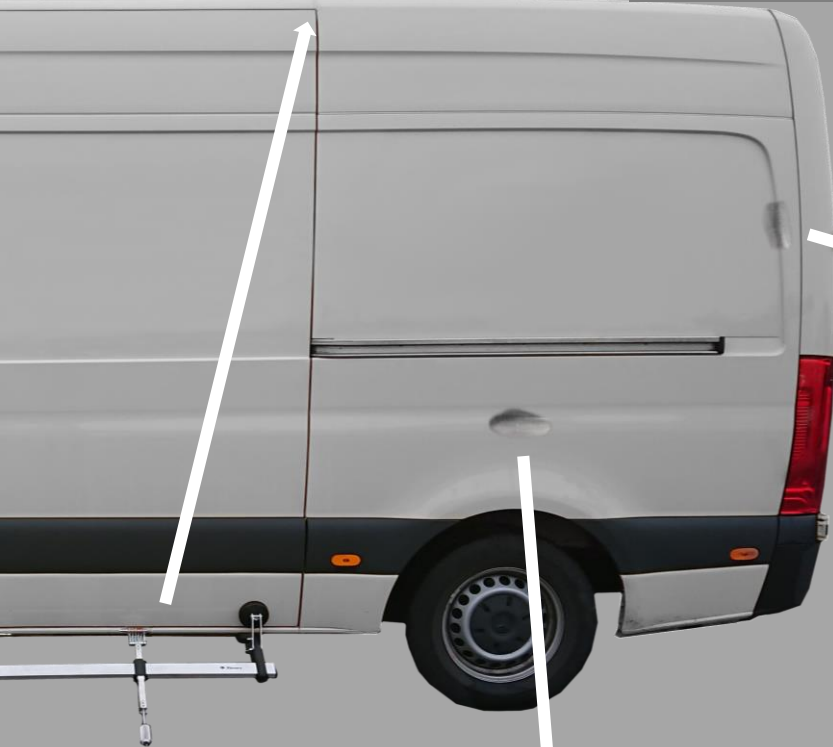

Welding Spares/Accessories

Stanners stocks a wide range of parts, from MIG Tips, Wire spools, Shrouds, Torches, Regulators, as well an extensive range of machine components, spares and consumables.

MIG Wire

Specialist Wire for manufacturers also available upon request.

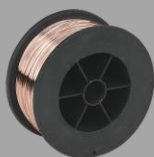

Steel Wire

Available in a wide range of sizes.



Aluminium Wire

Available in a wide range of grades and sizes.



Brass Wire

Available in a range of sizes.

MIG Tips

Standard Duty

Available in 0.6, 0.8, 1.0 and 1.2mm



Heavy Duty

Available in 0.8, 1.0 and 1.2mm



Regulators

CO2, Argon, Nitrogen and more!



Portable Weld Screens

Heavy duty, mobile welding screens, available in various colours and sizes.



Common Drill Consumables *More sizes available*



Boron Steel Drill 8.00x44
(Order ref: DF404730)



Boron Drill 8.00x80
(Order ref: DF244809)

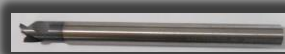

Boron Steel Drill 6.70 x 80
(Order ref: DF404740)



Cobalt Spot Weld Drill 6.00x80
(Order ref: DF244107)

Welding Helmet

Various Models available



Welding Gloves

Various Sizes available



Welding Blanket

Various Sizes available



Torch Liner

Various sizes available



Gas Shrouds

Various Sizes available



Range Of Rivet Air Tools

The fastest method of fastening which uses the precision of the driving force to create the perfect finish. Range of tools to suit your requirements from leading manufacturers. We have a wide range of Rivet Air Tool options available to choose from. We have tooling which can set Standard & Structural Rivets. Our range is from the industries leading manufacturers such as: FAR | Gesipa. Ask for a quote today.



REF: RAC171



REF: T4



Various rivets available for all types of bodyshop work.

Alu/Steel Dent Pulling Consumables

Steel Miracle Tips



Miracle Tip pk.1
Order Ref: **STA177**

Steel Consumable Washers/Spot Pulling



Pk.100 Small Triangles
Order Ref: **STA733**



Pk.100 Star Washers
Order Ref: **STA732**

Steel Slide Hammer + Stars



Pulling Stars pk.20
Order Ref: **STAF015/20**



1.1KG Slide Hammer
Order Ref: **STA111 + STA113**

Steel Threaded Studs



Stud Size	Order Reference
M4 x 12mm	EL408604
M4 x 16mm	STA109
M5 x 18mm	EL408605
M6 x 20mm	STA768
M6 x 12mm	EL408606

Steel Firtree Studs



Stud Size	Order Reference
5.5mm x 9mm	EL410082
5.5mm x 14mm	EL408568
5.5mm x 18mm	EL408569
5.5mm x 25mm	EL408570

Steel Keys and Rods



Straight Keys pk.100
Order Ref: **STAF030/100**



Twisted Keys pk.100
Order Ref: **STA734**



Pk.4 Pulling Rods
Order Ref: **STA747**

Steel Quick Puller Electrodes



Pulling Electrodes
Order Ref: **STA767**

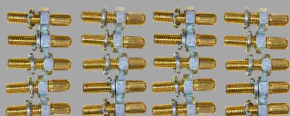

Quick Puller / Flatliner
M5 Electrodes pk.20
Order Ref: **STA735**

Steel Tempering

Carbon Rods pk.5
Order Ref: **STAF007/5**



Steel Wavy Wire

Wavy Wire pk.50
Order Ref: **STAF006/50**

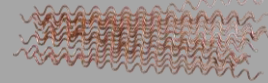

Electrode for Wavy
Wire Welding
Order Ref: **STA766**



Steel Single Sided Spot Welding

Single Sided Electrode
Order Ref: **EL417893**



12mm Domed Caps pk.6
Order Ref: **EL414320**



Universal Replacement Dent Pulling Claws

Heavy Duty Short
Order Ref: **STAF014HS/HD**



Standard Duty Long
Order Ref: **STAF014HL**

Standard Duty Short
Order Ref: **STAF014HS**



Heavy Duty Long
Order Ref: **STAF014HL/HD**

Aluminium-Silicon Studs

Alu 12% Silicon
Studs available in
various sizes.



Stud Size	Order Reference
M4 x 12mm	STA115 pk.200
M4 x 15mm	STA743 pk.50
M5 x 12mm	STA105 pk.100
M6 x 15mm	STA745 pk.50

Aluminium-Magnesium Studs

Alu 5% Magnesium
Studs available in
various sizes.



Stud Size	Order Reference
M4 x 12mm	STA114 pk.200
M4 x 15mm	STA744 pk.25
M5 x 12mm	STA106 pk.100
M6 x 15mm	STA746 pk.25

Aluminium Keys

Alu Straight Keys

Pk.50 Al-Mg - **REF:STA758**
Pk.50 Al-Si - **REF:STA757**



Alu Twisted Keys

Pk.25 Al-Mg - **REF:STA762**
Pk.25 Al-Si - **REF:STA761**



Aluminium 360 Pull Ring Kit **REF:STA736**

This boxed kit comes complete with 10x M4 and 10x M6 Keys, spinning 360° for narrow fitment and fast fit/removal on aluminium weld studs.



Many more consumables available – Ring the office for details!

Dent Repair Tools

Lever Puller **REF:STA749**



Strong lever puller with 6 hook claw, suitable for heavy duty dent pulling.

Slide Hammer c/w 4 Hook Claw **REF:STA748**



Slide hammer with 4 hook claw for manual pulling of dents.

Quick Puller **REF:STA751**

Complete with 4 choices of quick fit feet, this quick puller attaches directly to the gun for fast dent pulling. (Uses **STA735** electrodes)



Weld-On Slide Hammer **REF:STA111+113**



Weld-On Slide hammer for direct gun connection. (Use with **STAF015/20** pulling stars for dent pulling.)

Quick Puller Deluxe **REF:STA217**

Heavy Duty Quick Puller suitable for a range of tasks. (Uses **STA767** Electrodes)

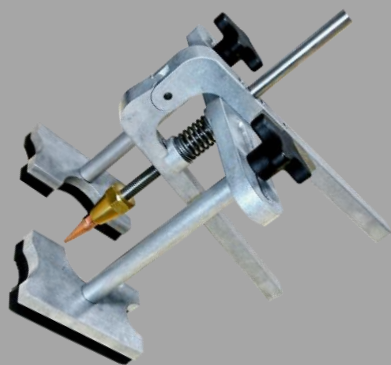

Suction Puller **REF:STAF067**



Air suction slide hammer PDR tool. Connect to workshop air supply - great for initial panel reshaping.

Push On Earth **REF:STA738**



Replacement high-contact quick release push-on, twist off earth.

Rapid Tab Shooter **REF:STA742**

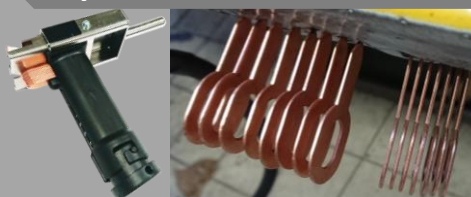

Quickly apply pulling keys closer together without having to load a single key each time. (Uses **STAF030/100** Keys)

H Puller **REF:STA764**



Attaches directly to the weld gun, allowing rapid pulling of dents. (Uses **STA735** Electrodes)

Operation:

- 1.Preset**
- 2.Press and weld**

Bright and clean
Tight
Keep space
- 3.Pulling**
- 4.Twist off**

360°

Product feature:
360° weld & pull directly

Stanners TKR XT2 accessories

The TKR XT2 is available with a wide range of accessories to allow use across various sections of the vehicle.

Flowform kit **TKR-STA-168**



Flow Form Die Ø6mm
Marking – Blue
Part No: TKR25-9

Flow Form Mandrel Ø6mm
Marking – Blue
Part No: TKR25-10



Flow Form Die Ø8mm
Marking – Orange
Part No: TKR25-12



Flow Form mandrel Ø8mm
Marking – Orange
Part No: TKR25-13



Reshaping Die
Marking – Violet
Part No: TKR25-15



Spanner Kit
SW16/SW20
Part No: TKR25-18



Integral Forming die Ø6mm
Marking - Green
Part No: TKR25-11



Integral Forming die Ø8mm
Marking - Yellow
Part No: TKR25-14



Piercing Mandrel
Marking - Red
Part No: TKR25-17



Piercing Die
Marking - Red
Part No: TKR25-16



Holder
Part No: TKR25-32

Each pair is colour coded for easy identification.

JLR RivKit **TKR-STA-237**



Rivet Removal Die 3.2mm
Marking – Green
Part No: TKR25-191

Rivet Removal Mandrel 3.2mm
Marking – Green
Part No: TKR25-192



Rivet Removal Die 5.3mm
Marking – Yellow
Part No: TKR25-193



Rivet Removal Mandrel 5.3mm
Marking – Yellow
Part No: TKR25-194



Flattening/Pressing In Anvils
Marking – Purple
Part No: TKR25-15



Spanner Kit
SW16/SW20
Part No: TKR25-18



Rivet Holder 3.2mm
Marking – Pink
Part No: TKR25-197



Rivet Holder 5.3mm
Marking – Pink
Part No: TKR25-198



PIP Anvil
Marking – Pink
Part No: TKR25-187



Shallow Bottom Anvil
Marking – Pink
Part No: TKR25-189



Flat Bottom Anvil
Marking – Pink
Part No: TKR25-188



5.3mm x 11mm
Rivet Removal Die
Marking - Pink
Part No: TKR25-195



Holder
Part No: TKR25-32



5.3mm x 11mm
Rivet Removal Mandrel
Marking - Pink
Part No: TKR25-196

Stanners TKR XT2 accessories

The TKR XT2 is available with a wide range of accessories to allow use across various sections of the vehicle.

Accessories & Consumables

Punching kit **TKR-STA-167**



Included in Standard Kit



Punching Die Ø6mm
Marking – Green
Part No: TKR25-4



Punching Die Ø8mm
Marking – Yellow
Part No: TKR25-7



Punching Die Ø6mm
Marking – Green
Part No: TKR25-3



Punching Die Ø8mm
Marking – Yellow
Part No: TKR25-6



Slide Bush Ø6mm
Marking – Green
Part No: TKR25-2



Slide Bush Ø8mm
Marking – Yellow
Part No: TKR25-5



Punching Die Holder
Part No: TKR25-8



Spanner Kit
SW16/SW20
Part No: TKR25-18

Each pair is colour coded for easy identification.

XT2 Trolley **STA169**

The advanced trolley for the TKR XT2 is the ideal addition to keep your riveter and all the accessories safe and tidy.

With 2 lockable draws and a lockable lower storage section, the XT2 and all the accessories including the blind riveter kit can be securely stored and organised.

The gun can be safely hung on the side of the unit, along with the various arms for ease of use between tasks in the workshop.



Optional Extra

Rivet Clamp NB45 **TKR-STA-1085**

Length	120mm
Width	75mm
Height	160mm
Clamp Opening	80mm
Opening Depth	45mm
Weight	2.5kg



Included in Standard Kit

Rivet Clamp NB130 **TKR-STA-1086**

Length	230mm
Width	75mm
Height	210mm
Clamp Opening	80mm
Opening Depth	130mm
Weight	6.2kg



Optional Extra

Rivet Clamp NB240 **TKR-STA-1087**

Length	390mm
Width	75mm
Height	350mm
Clamp Opening	140mm
Opening Depth	240mm
Weight	11.6kg



Optional Extra

Adaptors for XT2 10T + PNP90 6T anvil interchange



Short Adaptor
(for easy access)
Part No: TKR25-107

Standard Adaptor
Part No: TKR25-73

Distance Bolt
Part No: TKR25-74

These specially designed force limited adaptors allow you to use your current 6 ton anvil heads from the PNP90 on your XT2 unit.

BMW Anvils for 3.5mm and 5.0mm rivets



3.5mm Rivets
Die and Mandrel Set
Part No: TKRBGR-24

5.0mm Rivets
Die and Mandrel Set
Part No: TKRBGR-23

These sets must be used with the 10T/6T adaptors for use on the XT2.



Spanner Set
Part No: TKR-239

Stanners TKR XT2 accessories

The TKR XT2 is available with a wide range of accessories to allow use across various sections of the vehicle.

Audi/VW Kit **TKR-UNRK-2**



- 
R1 Mandrel
Part No: **TKR01-3372**
- 
R2 Mandrel
Part No: **TKR01-2976**
- 
R3 Mandrel
Part No: **TKR01-3373**
- 
R4 Mandrel
Part No: **TKR01-3374**
- 
R5 Mandrel
Part No: **TKR01-2979**
- 
R6 Mandrel
Part No: **TKR01-3375**
- 
R7 Mandrel
Part No: **TKR01-3376**
- 
R8 Mandrel
Part No: **TKR01-3377**
SOLD INDIVIDUALLY
- 
R9 Mandrel
Part No: **TKR01-3378**
- 
R10 Mandrel
Part No: **TKR01-3379**
- 
R11 Mandrel
Part No: **BGR-TKR-851**
- 
R12 Mandrel
Part No: **TKR01-3383**
- 
R13 Mandrel
Part No: **TKR01-3384**
- 
R14 Mandrel
Part No: **TKR01-3385**
- 
R15 Mandrel
Part No: **TKR01-3386**
- 
R16 Mandrel
Part No: **TKR01-3387**
- 
R17 Mandrel
Part No: **TKR01-3388**
SOLD INDIVIDUALLY
- 
Spanner Set
Part No: **TKR-239**

Audi/VW Kit (cont)

- 
P1 Mandrel
Part No: **TKR01-2977**
- 
P2 Mandrel
Part No: **BGR-TKR-244**
- 
P3 Mandrel
Part No: **TKR01-3389**
- 
P4 Mandrel
Part No: **TKR01-2978**
- 
P5 Mandrel
Part No: **TKR01-2980**
- 
P6 Mandrel
Part No: **BGR-TKR-245**
- 
P7 Mandrel
Part No: **TKR01-3390**
- 
P8 Mandrel
Part No: **TKR01-3391**



Stanners I-Range Heat Inductors

Stanners Equipment offers a range of Induction heaters for a wide variety of purposes, from automotive, agricultural, aerospace, industry maintenance etc.

An important feature of the induction heating process is that the heat is generated inside the object itself, instead of by an external heat source via heat conduction.

This works by using an electromagnet on the tool, inducing eddy currents within the target material, rapidly heating up the item. This means that only the target material is heated up and not any surrounding objects, making it safer to use around delicate components nearby e.g. rubber bushes, o-rings, seals etc.

Stanners i4s Heat Inductor



Why the Stanners i4-S Heat Inductor?

- 240V, 16A single phase Heat Inductor
- 5 Step Power Control
- IP21 Rating
- Liquid Cooling with heat exchanger for high duty cycle
- Lightweight unit on a mobile trolley, ideal for movement around the workshop

Technical Information

- 3.5kW Induction Power
- Weight – 13kg (excluding trolley)
- 240v Single Phase Supply
- 3Mtr Torch
- 2Mtr Mains Lead

REF: STA/i4s

Standard Tip

Fitted as standard to the i4s, this versatile tip offers high heat output in a wide range of situations.

Comes fitted with a user-replaceable ferrite tip for long term reduced consumable cost to the user.

Inline Tip

Available as an option for the i4s, this narrow fitment allows the i4s to be used in difficult access points.

Comes fitted with a user-replaceable ferrite tip for long term reduced consumable cost to the user.



REF: STA/IND-35/S03V

Stanners i13 Heat Inductor

Ideal for workshops or fields that require high-end heat levels.

The Stanners i13 is ideal for a wide range of applications for automotive use and more.

The i13 has a hydraulic heat exchanger with fan for excellent duty cycles, up to 45 mins constant use.

With variable output levels and simple controls for ease of use.

Ideal for automotive uses such as:

- Track Rod Ends
- Exhausts
- Suspension Components
- Pre-Heating hubs for bearing removal
- Removal/Unlocking seized nuts/bolts
- Straightening Drive Shafts
- Straightening + pre/post heating.
- Manifold stud heating
- And much more!

Technical Information

Rated Voltage	400V 3ph 50Hz 32A
Working Frequency	15-30khz
Duty Cycle	45min continuous use @ room temperature 20 deg.
Cooling System	20l Fan assisted cooling
Output Power	13kw
Degree of protection	IP21
Torch Length	4.25 Metre



REF: STA/I13S

Stanners i18 Heat Inductor

Ideal for workshops or fields that require high-end heat levels.

The Stanners i18 is ideal for a wide range of applications for heavy automotive use and more.

The i18 has a hydraulic heat exchanger with fan for excellent duty cycles, up to 60 mins constant use.

With 5 output levels and full colour touch screen controls for ease of use.



Technical Information

Rated Voltage	400V 3ph 50Hz 30A
Working Frequency	15-30khz
Duty Cycle	60min continuous use @ room temperature 20 deg.
Cooling System	20l Fan assisted cooling
Output Power	18kw
Degree of protection	IP21
Torch Length	4.5 Metre

REF: STA/I18S

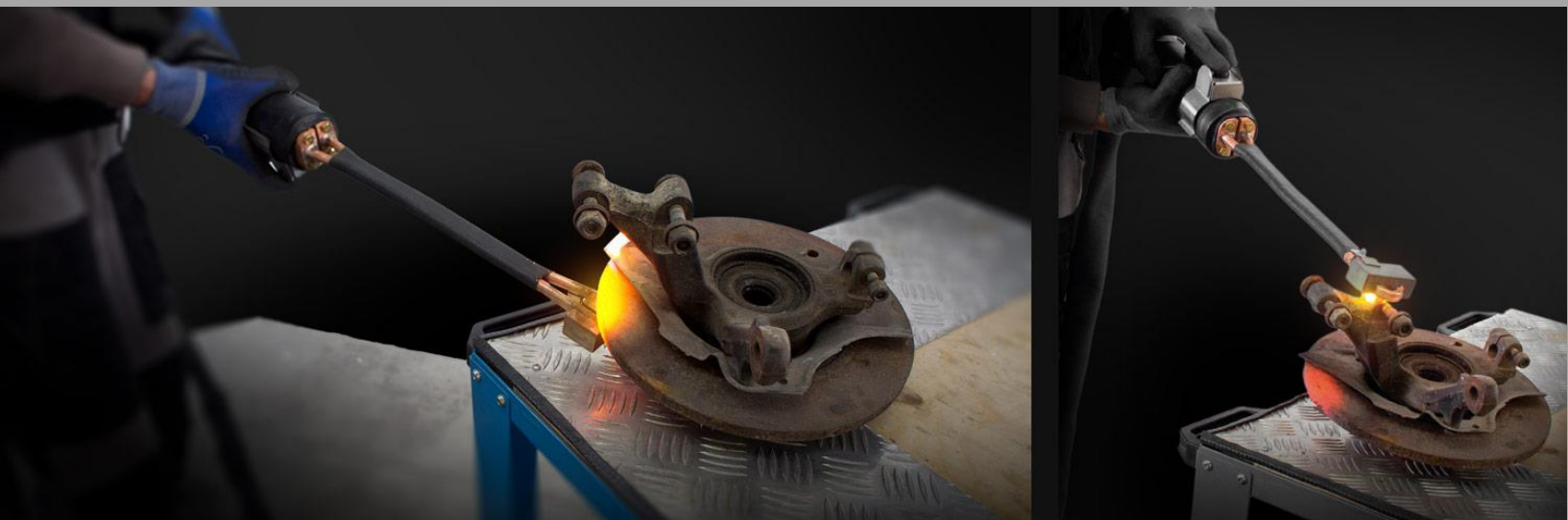

Stanners TKR Universal Walnut Blaster

The TKR Walnut Blaster is used to treat the surface of inlet channels and valves, removing carbonized material without affecting the metal surface by using a pressurised jet of walnut granules.

Compressed air is used to propel the blast medium – a pressure regulator for adjusting the air pressure with an integrated water separator is included in the scope of delivery.

Why Walnut Granules?

Nut shell granules are a natural product made from purified, ground walnut shells which are used as a blast medium for the gentle cleaning of surfaces.

Due to the low hardness and low specific weight, no material is removed from the workpiece.

When cleaning internal combustion engines, due to the organic nature of Walnut shell, any residual blast medium simply burns away without residue.



Universal Suction adaptors for vertical and horizontally installed motors.

Blast Media Available
REF:STA900

https://youtu.be/8qvCsa_kAb8



Watch this product in action!

- Weight: 16KG
- Hose Package Length: 4 Metre
- Max Operating Pressure: 8 BAR/116psi
- Container Volume: 5 Ltr



REF: TKRSTA-236

Training and Weld Testing



Need Specialised Training? That's where we can help.



With a nationwide team of weld testing/training staff, Stanners specialised Services visit you ON SITE to complete any training/testing, saving you the hassle and expense of booking accommodation and transport for your staff.

Destructive testing is carried out on site for same day results for standard BS Weld Tests.

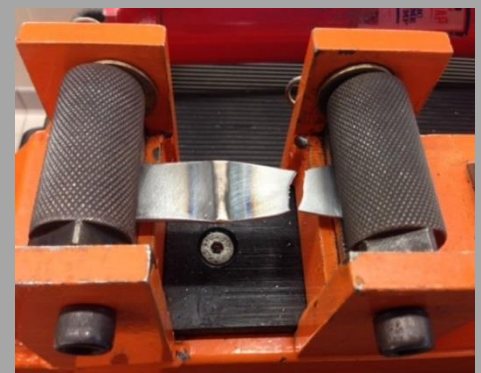

Car/Light Commercial Weld Training

ATA - AOM009

VWG Training Programme

Boron Steel Awareness

Aluminium Welding

Heavy Commercial Weld Testing

ATA - AOM133

ATA - AOM030

ATA - AOM006

Training centre for Exhaust pipe welding in Steel/Stainless steel



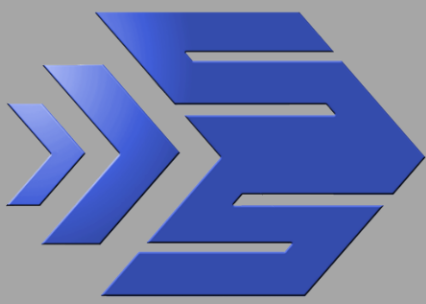

Stanners

E Q U I P M E N T L T D

Founded in 1957



Stanners Equipment

Coopies Lane Industrial Estate

Morpeth

Northumberland

NE61 6JN

Telephone: 01670 514133

Fax: 01670515492

Email: Stanners@Stanners-Equipment.co.uk

Web: www.stanners-equipment.co.uk



ABP Capital Equipment Supplier Winner 2022